



TECHNAUTICS, INC.

MARINE REFRIGERATION

**MARINE REFRIGERATION
INSTALLATION & MAINTENANCE
MANUAL FOR THE**

“Global 12”

***TECHNAUTICS, INC.
MARINE REFRIGERATION***

Phone 800 568 8979

Phone 949 645 3861

Fax 949 645 3230

www.technauticsinc.com

info@technauticsinc.com

TECHNAUTICS, INC.

“Model 12110 SP-1E” Engine Driven and “Cool Blue” 12v DC Refrigeration Systems

Table of Contents

Forward	1
Theory of Operation.....	3
Description.....	4
Additional Parts Required.....	5
Installation (A) Fin/Tube Stainless Steel Plate Assembly with Expansion Valve	6
Installation (B) Electrical Control Panel	7
Installation (C) Thermostat	8
Installation (D) Engine Driven Compressor	9
Installation (E) Condenser/Receiver-Drier/Filter Assembly.....	10
Installation (F) 1/4” Tubing and Rubber Hoses for Engine Driven Compressor System	11
Installation (G) 12v DC “Cool Blue” Compressor Unit.....	12
Installation (H) 1/4” 12v DC Tubing Assembly	12
Installation (I) 3/8” 12v DC Tubing Assembly.....	13
Technautics Limited Warranty	13
Electrical Wiring Diagram	14
System Preventive Maintenance	15
Freon Charging Instructions	16
Engine Driven Compressor System.....	16
Cool Blue 12v Compressor System	17
Wire Size Guide.....	18
Cool Blue Compressor System Description.....	19
General	19
Electrical Connections	19
Cable Dimensions.....	20
Thermostat Connection.....	20
Fan Connection.....	21

Forward

This manual covers the “Model 12110 SP-1E” Engine Driven and the “Cool Blue” 12v DC Marine Refrigeration Systems. *Read all instructions in this manual before installation.*

There are nine major components, listed below, for the dual system supplied by Technautics. System components are fitted with Aeroquip connectors. The system comes entirely pre-charged with refrigerant; therefore, with the use of the Aeroquip connectors, installation is a simple process. No more refrigerant has to be added to the system after installation. Also, the system is designed so that no refrigeration technical experience is necessary.

CAUTION: *Do not damage tubing or hose. Do not remove Aeroquip connectors. This will result in contamination and loss of refrigerant.*

Supplied components:

1. Fin/Tube Plate with Expansion Valve



2. Electrical Control Panel



3. Thermostat

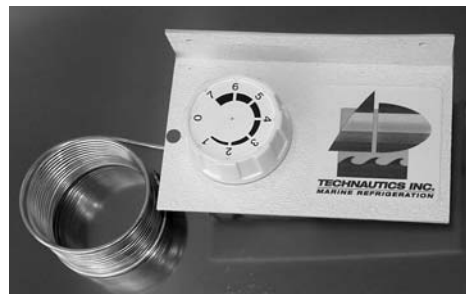

4. Model 12110 SP-1E Engine Driven Compressor Unit with Suction and Pressure Hoses (hoses not shown)



5. Condenser/Receiver-Drier/Filter Assembly



6. 1/4" Tubing Assembly for Plate to Condenser/Receiver-Drier/Filter Assembly Connection



7. Cool Blue 12v DC Compressor Unit



8. 1/4" 12v DC Tubing Assembly



9. 3/8" 12v DC Tubing Assembly



Additional parts are required to install the Technautics system. These are specified in the "Additional Parts Required" section of this manual.

Theory of Operation

Starting with the liquid refrigerant ahead of the evaporator at Point A, the admission of liquid to the evaporator is controlled by an automatic throttling device (expansion valve) that is actuated by temperature and pressure. The refrigerant pressure is reduced across the valve from high pressure (Point A) to the evaporator pressure (Point B). The valve acts as a boundary between the high and low-pressure sides of the system.

The low-pressure liquid expands, absorbs heat from the eutectic solution, and begins to evaporate. The refrigerant liquid and vapor passing through the evaporator coil continues to absorb heat until it is completely evaporated and turns into gas (Point C). The heated gas is drawn through the suction line to the compressor suction (Point D). The increased pressure produced in the compressor causes the gas to heat and flow into the condenser (Point E). In the condenser, the cooling water absorbs heat to condense the hot gas back to liquid form. The liquid refrigerant is collected (Point F) through the filter/drier and is available to begin the cycle again.

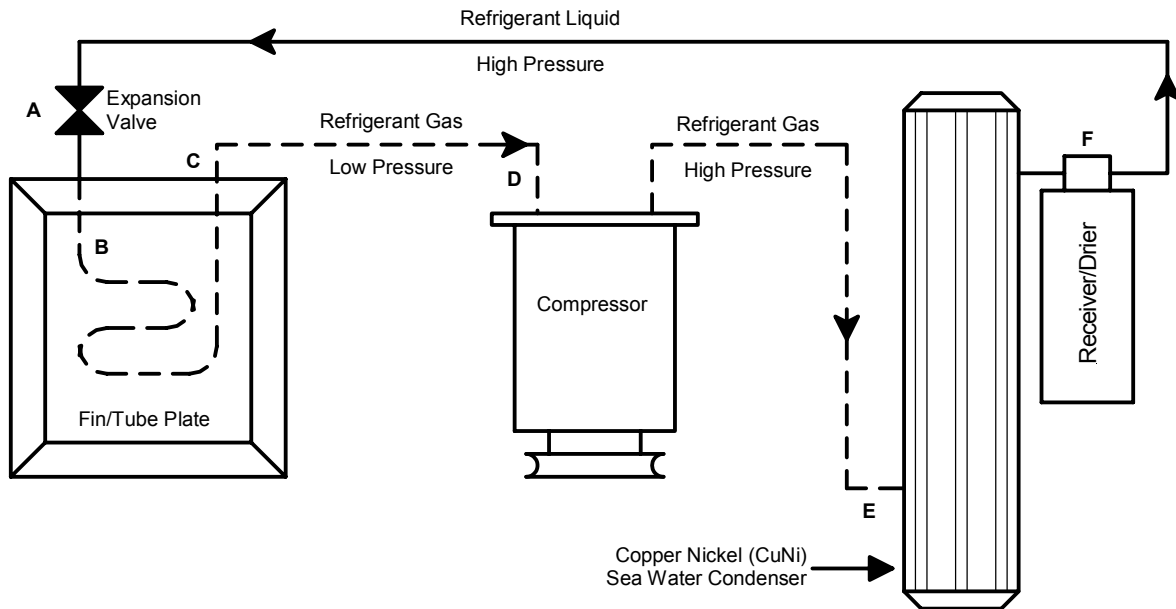

THEORY OF REFRIGERATION

Description

The Model 12110 SP-1E and "Cool Blue" are systems that can be utilized for a one box refrigerator, one box freezer, or a combination single box with thermal divider. The thermal divider should be 1" to 2" polyurethane foam covered with fiberglass, ABS plastic or Formica. Air passages cut through in the divider can be lined with PVC or a similar tubing material, trimmed to length, and caulked. This will protect the insulating material from moisture penetration.

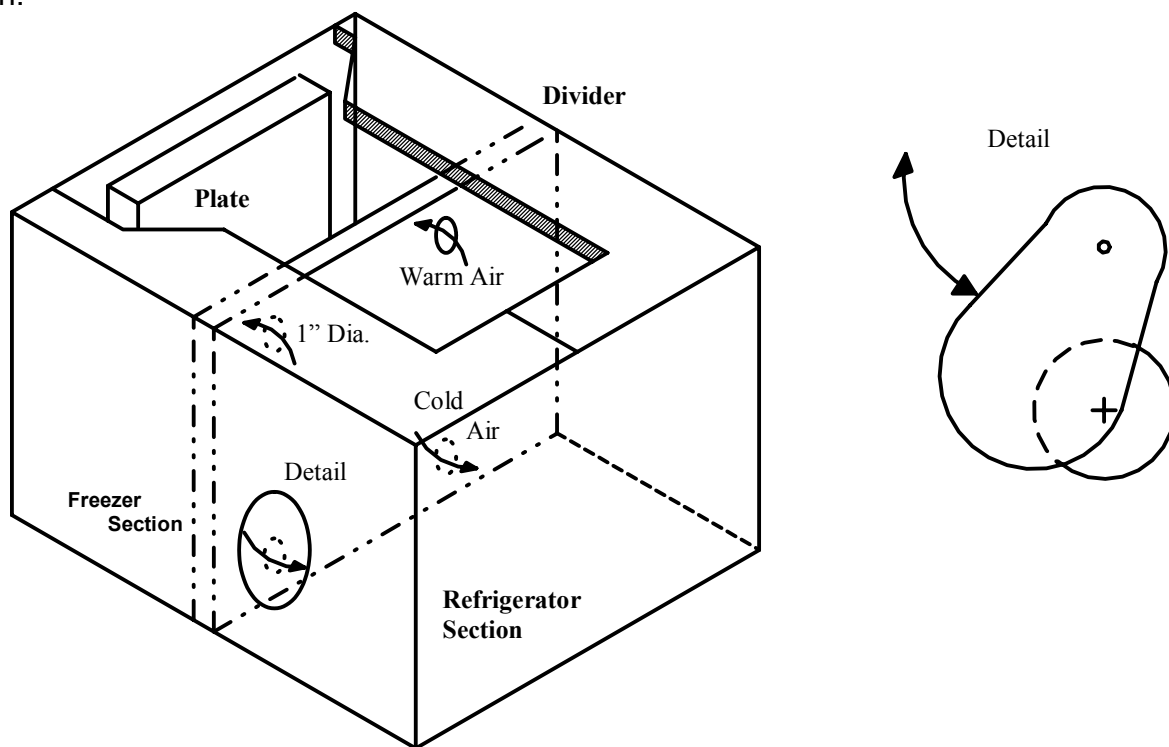

Single Box with Thermal Divider

Model 12110 SP-1E consists of:

1. Fin/Tube stainless steel plate assembly with Aeroquip connectors and expansion valve (Part #12110 SP-1E.1)
2. Engine driven compressor and hose assembly with Aeroquip connectors (Part #12000 SP-1E.2)
3. Condenser/Receiver-Drier assembly (Part #12000 SP-1E.3) with filter (Part #12000 SP-1E.3.1)
4. Two 1/4" tubing assembly (Part #12000 SP-1E.4)
5. One 3/8" Tubing Assembly (Part #12000SPIE.6)
6. Electrical Control Panel (Part #12000 SP-1E.5)
7. 12 Volt CoolBlue Condensing Unit (Part #0011012spie.5)
8. Thermostat (Part #12110SPIE.8)

Additional Parts Required

ENGINE DRIVEN COMPRESSOR:

1. 4" – 6" power take off pulley for engine.
2. 7/16" wide pulley belt, length to suit.
3. Compressor mounting bracket (typically steel) and bolts. Technautics offers for sale a universal compressor bracket.

CONDENSER/RECEIVER ASSEMBLY:

1. Wire reinforced cooling water hose.
2. Stainless steel hose clamps.
3. Bronze pipe fittings as necessary.

ELECTRICAL WIRING

1. Wire per wiring diagram and installation instructions.

Installation (A) Fin/Tube Stainless Steel Plate Assembly with Expansion Valve

Part #12000 SP-1E.1

Location: Fin/Tube plate is installed into an existing refrigerator/freezer.

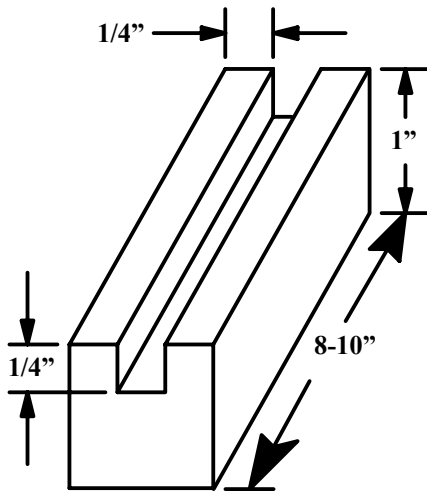

Mounting Channel

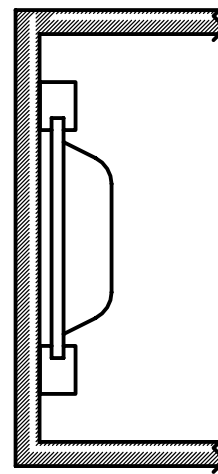

Mounting Channel Cold Plate

Caution: Do not drill through flange of stainless steel fin/tube plate.

1. Determine plate position in box to allow for air circulation around the plate. Plate may be mounted vertically or horizontally. The expansion valve must be to the top.
2. Position the plate so that it fits into the box with clearance for the lid, insulation, etc.
3. Drill a 2" diameter hole in the upper-most section inside the box to allow for tubing installation. Determine the best location for tubing with numbered Aeroquip connectors to enter box and line up with same-numbered Aeroquip connectors on plate.
4. Install bottom-mounting channel into side of existing box with self-tapping screws.
5. Mount plate into bottom mounting channel.
6. Mount top or side mounting channel to hold plate in place with self-tapping screws.

Installation (B) Electrical Control Panel

(Part #12110 SP-1E.9)

Location: Any convenient location.

Additional Parts Required: AWG wire.

1. If the engine driven compressor is not grounded, run correctly sized AWG wire (see Wire Sizing Guide) from the compressor to a common ground.
2. Bond the condenser/receiver assembly to the vessel bonding system to mitigate electrolysis damage
3. Run the rest of the system as indicated on the following diagram.

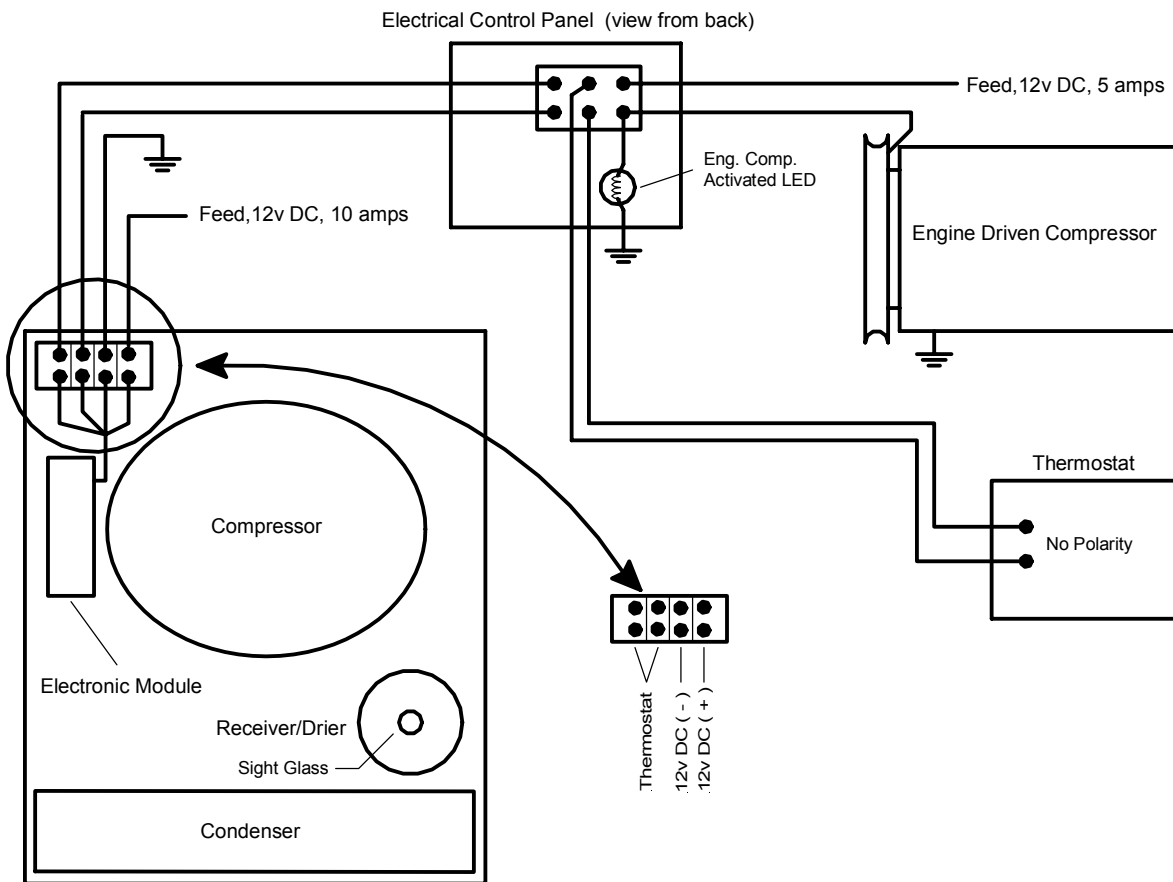

WIRING DIAGRAM

Installation (C) Thermostat

(Part #12110 SP-1E.8)

Warning: Do not kink small thermostat tubing.

Location: Any convenient location inside the cooling box to allow easy temperature adjustment yet close enough to permit the sensing tube to be inserted into the copper tubing on the size of the fin/tube plate.

1. Using two-sided tape or screws, mount the thermostat on any convenient surface inside the cooling box near the fin/tube plate.
2. Insert the sensing tube all the way into the copper tube receptacle on the side of the fin/tube plate.
3. Coil (see “Warning” above) and secure excess small tubing to prevent damage.
4. Use #16 AWG (min.) wire to connect the thermostat to the DC compressor, or the Electrical Control Panel if used in conjunction with an engine driven compressor.

*Caution: When used with the engine driven compressor, size the wire for a 5 amp load X **total length** of the engine driven compressor wiring system.*

5. Since the thermostat acts only as a switch, there is no polarity for the thermostat wire connections.
6. The knob settings on the thermostat range from 1 - 7, with 1 being cool and 7 being the coldest.

Installation (D) Engine Driven Compressor

(Part #12000 SP-1E.2)

Location: Mount near engine on a stringer, bulkhead or the engine itself. Ease of installation is achieved with multiple mounting points on the compressor body.

Additional Parts Required: 4" – 6" power take off pulley

7/16" wide pulley belt, length to suit

Fabricate a compressor bracket (usually steel) to fit installation

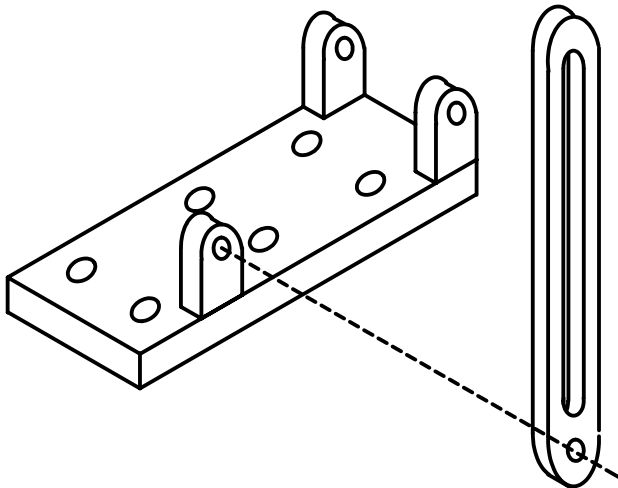

* Compressor Bracket & Adjusting Arm

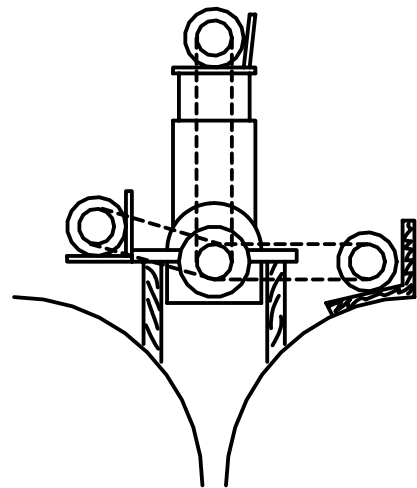

Compressor Mounting Locations

1. Install the 4" – 6" power take-off pulley on engine.
2. Mount compressor bracket in selected location. Allow for belt alignment adjustment.
3. Mount compressor on bracket using 3/8" diameter bolts or lag bolts.
4. Install the 7/16" wide belt compressor and engine power take-off pulleys.
Note: Only one belt is required for proper compressor operation.
5. Align the compressor pulley to the power take-off pulley and tighten the belt using the adjuster arm on the compressor. Tighten to 10 - 15 ft. lbs.

* Technatics has a pre-fabricated universal flat bracket available for purchase.

Installation (E) Condenser/Receiver-Drier/Filter Assembly

(Part #12000 SP-1E.3)

Location: On bulkhead near engine or engine raw water intake. This location must be within 5' of the compressor so the high-pressure hose from compressor will reach.

Additional Parts Required: Wire reinforced cooling water hose
Stainless steel hose clamps
Bronze pipe fittings

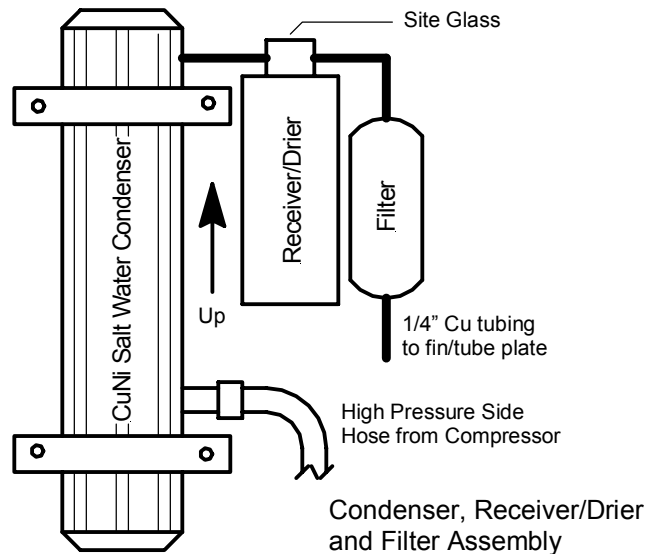

1. Install the condenser/receiver assembly vertically on a bulkhead near the engine and raw water intake.
2. Close the engine cooling water through-hull valve.
3. Remove hose between raw water strainer outlet and engine water intake.

Warning: If no raw water strainer is in the system, one must be installed. The Technautics warranty is void if no strainer is used.

4. Install new wire reinforced hose from the outlet of the strainer to the condenser inlet on the condenser/ receiver assembly. The condenser connections are 1" NPT. Use bronze fittings and pipe nipples to match the strainer outlet size. Direction of water flow in and out of the condenser should be up.
5. Similarly, using wire reinforced hose, connect the outlet of the condenser to the engine water intake.
6. Double clamp the hoses with stainless steel hose clamps.

Installation (F) 1/4" Tubing and Rubber Hoses for Engine Driven Compressor System

(Part #12000 SP-1E.4)

Important: To prevent contamination, do not remove protective caps from Aeroquip connector fittings until final connection is to be made.

Warning: Do not kink tubing or hose.

Location: From fin/tube plate to condenser/receiver assembly location.

1. Run the 1/4" copper tubing with numbered Aeroquip connector from condenser/receiver assembly through a 2" hole to the inside of the cooling box. Attach to the matching numbered connectors on the fin/tube plate and the condenser/receiver assembly. Tighten to 10 ft lbs.

NOTE: Install a piece of PVC or similar type tubing through the 2" hole, trimmed flush on each side and caulked. This will provide a better seal area and will protect the insulation from moisture penetration.

2. Run the small diameter rubber hose with numbered connector from the compressor and connect to the CuNi condenser. Tighten to 10 ft lbs.
3. Run the large diameter rubber hose from the compressor through the 2" hole to the inside of the cooling box and attach to the matching connector number on the fin/tube plate. Tighten to 35 ft. lbs.

Installation (G) 12v DC “Cool Blue” Compressor Unit

(Part #0011012 SP-1E.5)

Important: To prevent contamination, do not remove protective caps from Aeroquip connector fittings until final connection is to be made.

Note: Allow at least 3” of clearance around the condensing coils for free air circulation. If installed in a restrictive compartment, inlet and outlet vents equal in area to that of the condensing coils, should be cut to allow for free air circulation.

Location: Any convenient location that has sufficient air circulation over the condensing coils.

1. Mount the 12v DC compressor on a level platform. This location must be within 12 feet of the stainless steel fin/tube plate so the copper tubing will reach.
2. Do not install the compressor higher than 5 feet above the top of the stainless steel fin/tube plate.

Installation (H) 1/4” 12v DC Tubing Assembly

(Part #12000 SP-1E.4)

Important: To prevent contamination, do not remove protective caps from Aeroquip connector fittings until final connection is to be made.

Warning: Do not kink tubing.

Location: From DC compressor location to fin/tube plate.

1. Run the 1/4” copper tubing numbered Aeroquip connector from the 12v DC compressor through the 2” diameter hole to inside the cooling box. Attach to the matching numbered connector on the fin/tube plate. Tighten to 10 ft lbs.
2. Connect numbered connector on other end of copper tubing to the matching numbered connector on the 12v DC compressor. Tighten to 10 ft lbs.

Caution: Coil excess tubing and secure in a safe position to prevent damage to the tubing.

Installation (I) 3/8” 12v DC Tubing Assembly

(Part #12110 SP-1E.7)

Important: To prevent contamination, do not remove protective caps from Aeroquip connector fittings until final connection is to be made.

Warning: Do not kink tubing.

Location: From DC compressor location to fin/tube plate.

1. Run the 3/8” copper tubing numbered Aeroquip connector from the 12v DC compressor through the 2” diameter hole to inside the cooling box. Attach to the matching numbered connector on the fin/tube plate. Tighten to 10 ft lbs.
2. Connect numbered connector on other end of copper tubing to the matching numbered connector on the 12v DC compressor. Tighten to 10 ft lbs.

Note: Coil excess tubing and secure in a safe position to prevent damage to the tubing.

Technautics Limited Warranty

Technautics, Inc. warrants new equipment to be free from defects in materials and workmanship for five years from date of purchase. The warranty does not cover any merchandise or component thereof that, in the opinion of the company, has been subjected to negligent handling, misuse, alteration, an accident, or if repairs have been made with parts other than those obtainable through Technautics, Inc.

Parts of components being claimed for warranty must not be disassembled or any attempt made to repair them unless approval is given by Technautics. Breakage or damage resulting from installation or operation not in accordance with Technautics’ published installation and operating instructions are not covered by warranty.

Technautics does not warrant equipment and accessories not of our manufacture, that are warranted by their respective manufactures, and that are extended to the purchaser through Technautics, Inc.

Any Technautics part or component covered by this warranty, that in our judgement shows evidence of a valid defect, shall be returned to Technautics, Inc. or an authorized Technautics dealer, freight charges prepaid.

In no event shall Technautics be liable for contingent or consequential damages. This warranty is in lieu of all other warranties and is limited to the replacement of parts returned to the factory and determined defective on inspection. This warranty does not cover labor or freight costs incurred by the customer

Electrical Wiring Diagram

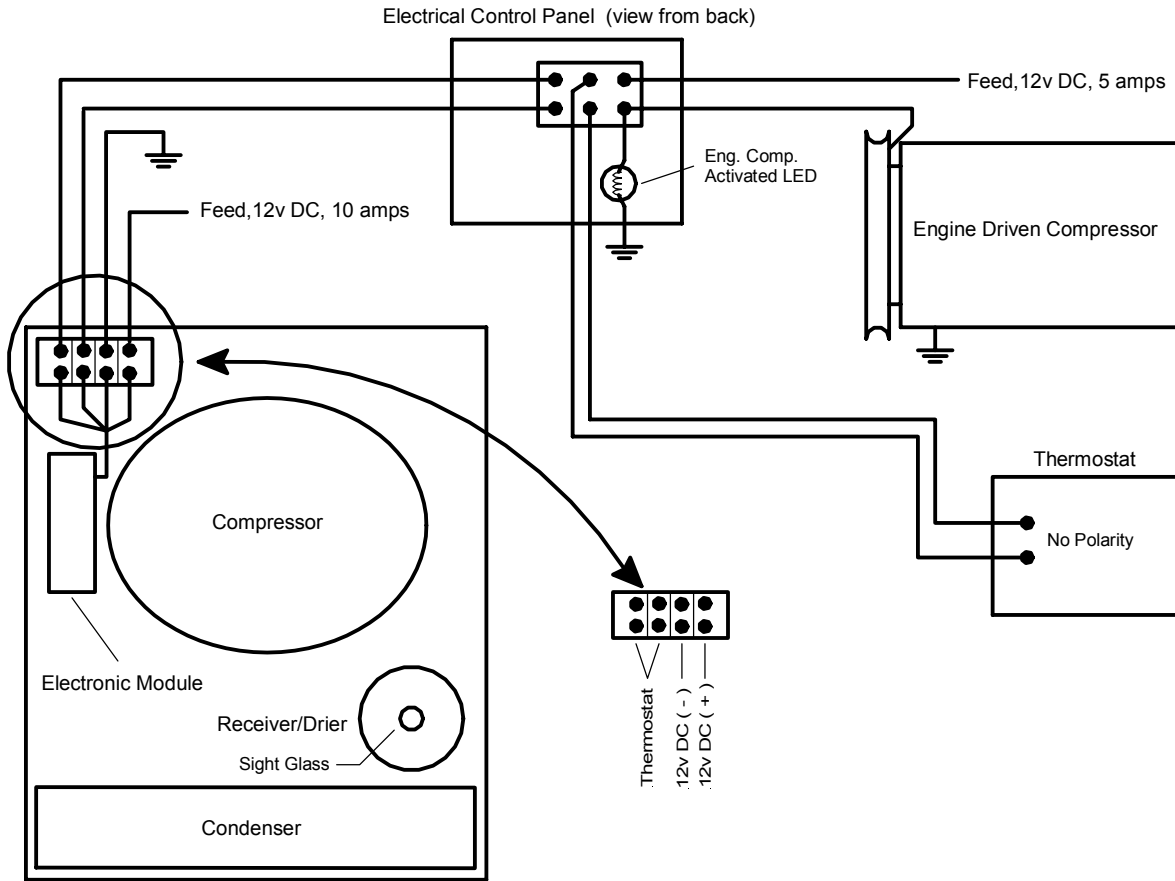

WIRING DIAGRAM

System Preventive Maintenance

Very little maintenance is required for efficient operation. Once or twice a year:

1. Check engine driven compressor belt for proper tension.
2. Check engine driven compressor bracket for tightness.
3. Check the flare nuts on the compressor(s) and fin/tube for tightness.
4. Check for oil around fittings (indicates a leak).
5. Change filter/drier annually (see schematic below for part number and additional instructions).

Additionally:

1. Run engine driven compressor at least once a month to lubricate its seals.
2. Check refrigerant levels monthly.
3. Clean condensing coil on Cool Blue DC unit every 6 months.
4. When the fin/tube plate is not in use, wipe it off to keep it clean.

Caution: Do not run the engine driven compressor for more than 2 hours at a time.

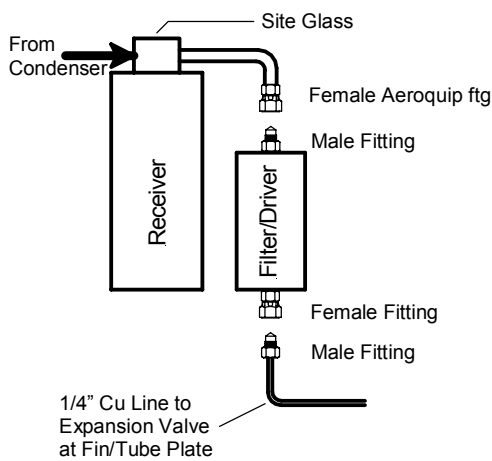

Remove filter by uncoupling the male & female connectors. Then change the fittings to the new filter and re-install the filter.

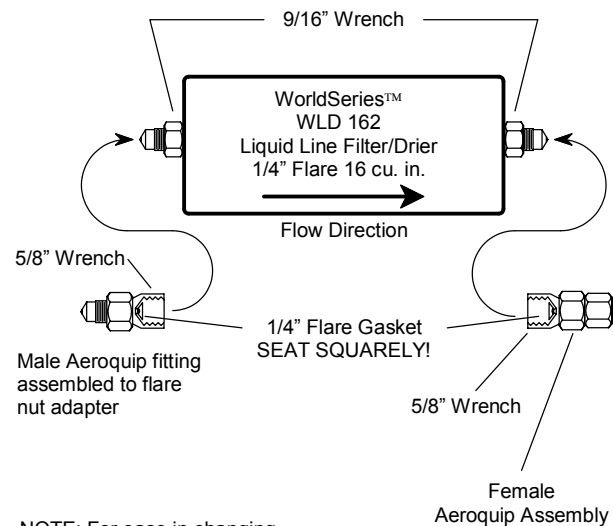

NOTE: For ease in changing fittings, hold filter in a vertical position. Do not overtighten fittings.

FILTER/DRIER CHANGE OUT

Freon Charging Instructions

Engine Driven Compressor System

Caution: Wear appropriate eye protection when charging the system.

1. Locate and identify the following:
 - A. Sight Glass – the 3/8" diameter glass window on top of the condenser/receiver.
 - B. Suction Service Valve – the 9/16" blue painted cap located on the compressor (in front of the large rubber hose and labeled by an "S" on the compressor body).

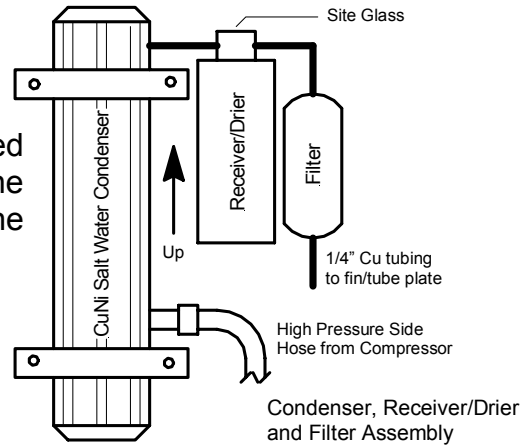

2. Start engine and run at about 1200 to 1500 rpms.
3. Set the switch on the Electrical Control Panel to the "Engine" position and adjust the thermostat as needed to make the compressor run.
4. Immediately look for flow in the sight glass (flow should occur within one minute).
5. After 10 minutes of operation, observe the sight glass. If bubbles are present, the system needs to be charged.
6. Tightly connect the charging hose to the refrigerant can.
7. Remove the blue cap from the suction valve and **very loosely** attach the charging hose to the suction valve.
8. Open the refrigerant can valve slightly and purge air from the charging hose for 2 to 5 seconds, then **firmly tighten** the charging hose to suction valve connection.
9. Open the refrigerant can valve fully to feed freon into the system until bubbles are no longer visible in the sight glass.
10. Continue running the system for 5 more minutes and look for bubbles in the sight glass. If bubbles are present, repeat step 9.

Note: Charge system only by using the sight glass, not by using a pressure gauge. A few bubbles are OK.

11. Repeat steps 9 and 10 until no more bubbles are visible.
12. The system is now fully charged. Reset the thermostat to its previous position.
13. Close the refrigerant can valve, disconnect the charging hose and replace the blue cap (finger tight), and turn off the engine.

Cool Blue 12v Compressor System

Caution: Wear appropriate eye protection when charging the system.

1. Locate and identify the following:
 - A. Sight Glass – the 3/8” diameter glass window on top of the receiver/drier by the compressor unit.
 - B. Sight Glass Suction Service Valve – the blue painted cap located by the compressor unit and receiver/drier.
2. Set the switch on the Electrical Control Panel to the “DC” position and adjust the thermostat as needed to make the compressor run.
3. After 10 minutes operation, observe the sight glass. If bubbles are present, the system needs to be charged.
4. Tightly connect the charging hose to the refrigerant can.

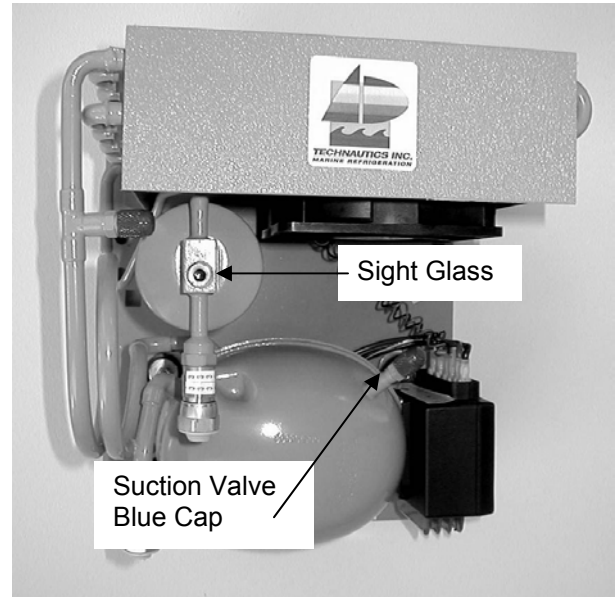

5. Remove the blue cap from the suction valve and **very loosely** attach the charging hose to the suction valve
6. Open the refrigerant can valve slightly and purge air from the charging hose for 2 to 5 seconds, then **firmly tighten** the charging hose to suction valve connection.
7. Open the refrigerant can valve fully to feed freon into the system until bubbles are no longer visible in the sight glass.
8. Continue running the system for 5 more minutes and look for bubbles in the sight glass. If bubbles are present, repeat step 7.

Note: Charge system only by using the sight glass, not by using a pressure gauge. A few bubbles are OK.

9. Repeat steps 7 and 8 until no more bubbles are visible.
10. The system is now fully charged. Reset the thermostat to its previous position.
11. Close the refrigerant can valve, disconnect the charging hose, and replace the blue cap (finger tight).

Wire Size Guide

Remember that an electrical load 10 ft. away is really 20 ft. away for wire size calculations.

AWG Wire Sizes for 12v Systems Based on a 3% Voltage Drop (Recommended for Voltage Sensitive Components/Motors)

Total Current on Circuit in Amps	Total Length in Feet										
	20	30	40	50	60	70	80	90	100	110	120
5	14	12	12	10	10	8	8	8	8	8	6
10	12	10	8	8	6	6	6	5	5	5	4
15	10	8	6	6	6	5	4	4	3	3	2
20	8	6	6	4	4	2	2	2	2	2	1
25	8	6	4	4	2	2	2	1	1	1	0
30	6	4	4	2	2	-	-	-	-	-	-
40	6	4	2	2	1	-	-	-	-	-	-
50	4	2	2	1	1/0	-	-	-	-	-	-

AWG Wire Sizes for 12v System Based on a 10% Voltage Drop (Not Recommended for Voltage Sensitive Components/Motors)

Total Current on Circuit in Amps	Total Length in Feet										
	20	30	40	50	60	70	80	90	100	110	120
5	18	18	16	16	16	14	14	14	12	12	12
10	16	16	14	12	12	10	10	10	10	10	8
15	16	14	12	10	10	10	8	8	8	8	8
20	14	12	10	10	8	8	8	6	6	6	6
25	12	10	10	8	8	8	6	6	6	6	4
30	12	10	8	8	8	-	-	-	-	-	-
40	10	8	8	6	6	-	-	-	-	-	-
50	10	8	6	6	4	-	-	-	-	-	-

The Global 12 Compressor System Description

General

The Danfoss refrigeration compressor, Type BD35F, is designed for connection to 12v and 24v systems and for refrigerant R134a (CF₃-CH₂F). The compressor can be used in refrigerators and freezers and is designed for a capillary tube as the throttling device.

The compressor is especially intended for use in mobile applications, e.g., pleasure craft, commercial shipping, buses, etc. It will operate under continual heeling of 30° such as occurs on yachts.

The compressor is used together with an electronic unit containing overload protection and protection against destructive battery discharge. The electronic unit has internal voltage recording and calibration to the applied voltage. Also, the electronic unit can be powered directly from certain types of electronic power supply units and thus no battery is required. In addition to being especially quiet in operation, the compressor has low energy consumption.

The BD compressor must be mounted in a dry and clean location. The compressor can withstand storage temperatures down to -31° F (-35° C).

Condensing temperatures:

Max. 140° F (60° C) at stable conditions and max. 158° F (70° C) at peak load.

Ambient temperatures: Min. 14° F (-10° C); max. 131° F (55° C)

Electrical Connections

The BD compressor is fitted with a brush-less direct current motor, which through an electronic unit becomes electronically commutated. The electronic unit is delivered separately and must be mounted on the compressor. Otherwise, all approvals and warranties become void. The electronic unit must always be connected directly to the battery poles. For installation protection an external fuse (max. 15A, blue) must be installed close to the battery (or power supply) in the positive supply wire. The wires to the battery must be connected with screws. Avoid extra wire splices/connections. Establish a special wiring circuit for the BD compressor.

If the wrong polarity is used, the electronic unit will not work. If the chassis is used as a ground path, good terminal connections of the appropriate size wire must be made.

The electronic unit will calibrate to the applied voltage. This means that if the source voltage is less than 17v, the system assumes that it is working in a 12v system. If the voltage is higher than 17v, the electronic unit assumes that it is working in a 24v system. Consequently, the compressor does not run at power supply voltages between about 17v and the desired battery protection cut out voltage for 24v systems.

To facilitate longer standstill periods a main switch can be installed. The switch must have a contact system suitable for a min. of 20 amps otherwise the voltage drop will cause the

battery protection to cut off the compressor sooner.

Cable Dimensions

To ensure correct start and operating conditions, the following cable dimensions must be observed:

Cable Cross-Section AWG (mm ²)	Max. Length* Ft (M)	
	12v System	24v System
14 (2.5)	8 (2.5)	16 (5)
12 (4)	13 (4)	26 (8)
10 (6)	20 (6)	39 (12)

* Distance between the power source and electronic unit, one way.

Thermostat Connection

The BD compressor can operate with normal mechanical type thermostats used in refrigeration appliances, or with electronic thermostats. Always use a new thermostat.

The thermostat is normally connected across terminals “C” and “T” of the electronic unit. Compressor current does not flow through the thermostat contacts. When the thermostat is open there will still be power on the electronic unit.

Normally, the compressor speed is pre-fixed to 2,000 rpm. However, the compressor speed (rpm) can be pre-set to a different fixed speed by connecting an optional resistor in series with the thermostat (7) (see Electronic Unit schematic). The speed is programmed with the resistor resulting in the currents in the wire. The value of the resistor for the corresponding speed can be seen in the table.

RPM	Current mA	Resistance Ω
2,000	5.15	0
2,000	5	20
2,500	4	277
3,000	3	692
3,000	2	1523

Alternatively, the speed of the compressor (2,000 to 3,500 rpm) can be calculated according to the following example:

Example for 2,200 rpm: $I_{rpm} = 5 - (2,200 - 2,000 / 500 = 4.6 \text{ mA}$
 $R_{rpm} = 1,000 - (0.139 + (2,200 - 2,000) / 516) / I_{rpm} = 114\Omega$

A compressor system with zero standby current can be established if the thermostat (6) is replaced by a short circuit, and the main switch (3) is replaced by a thermostat. In this case, the full current to the compressor flows through the thermostat, and the thermostat should be rated accordingly.

Fan Connection

A fan must be connected to the electronic unit terminals “+” and “F”. Always use a 12v fan, even in a 24v system, as the electronic unit will automatically reduce the applied voltage for the fan to 12v.

Maximum load on the electronic unit is 0.5 amps. The fan is allowed to start with a higher current for the first 2 seconds. If the fan becomes overloaded, both the fan and compressor will be cut out by the overload protection.

- 1. Electronic Unit
- 2. Battery
- 3. Main Switch (optional)
- 4. Used by Danfoss **only**
- 5. Fan (optional)
- 6. Thermostat
- 7. Resistor for pre-setting speed (optional)
- 8. Resistor for pre-setting battery protection voltage (optional)
- 9. Fuse

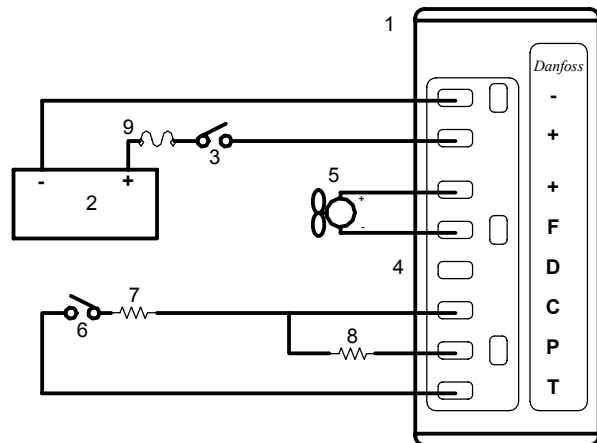

ELECTRONIC UNIT